

FRONT VIEW
WITHOUT DOOR

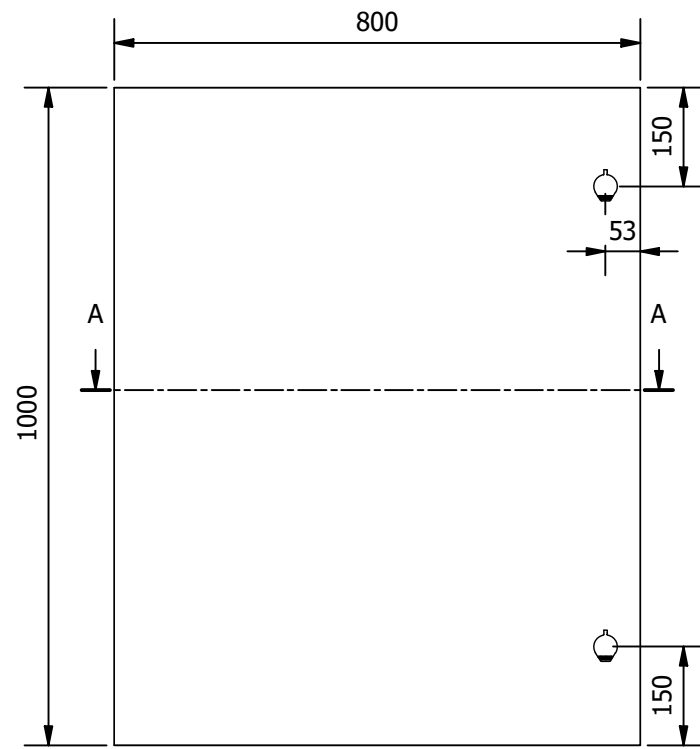

FRONT VIEW

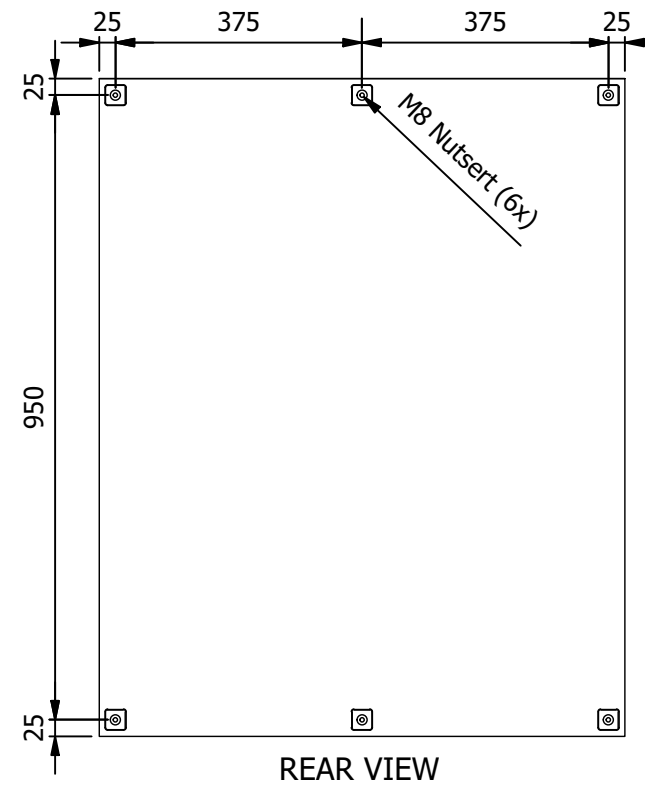

REAR VIEW

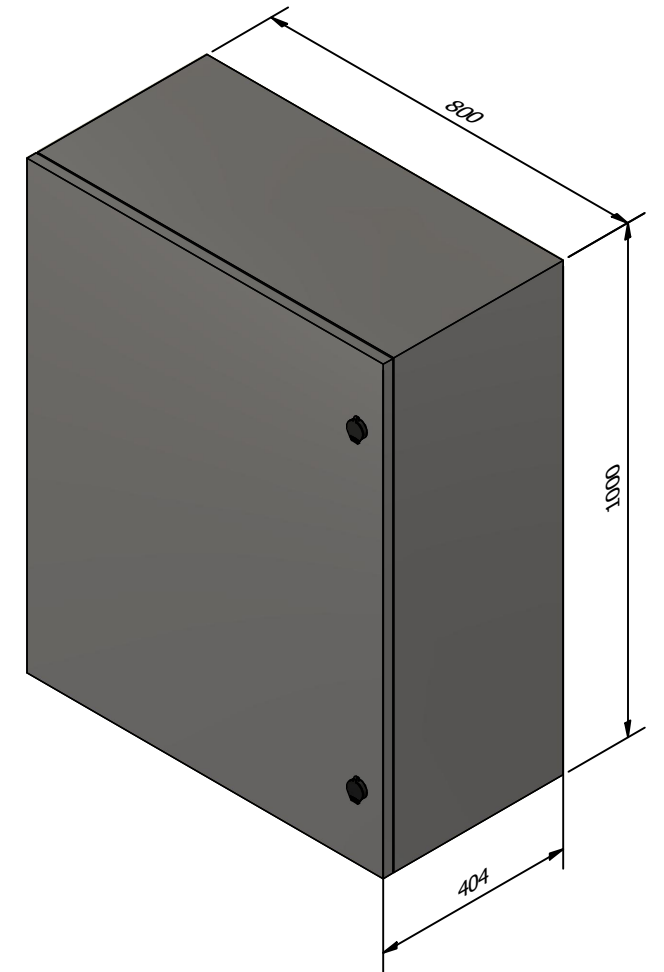

ISOMETRIC VIEW

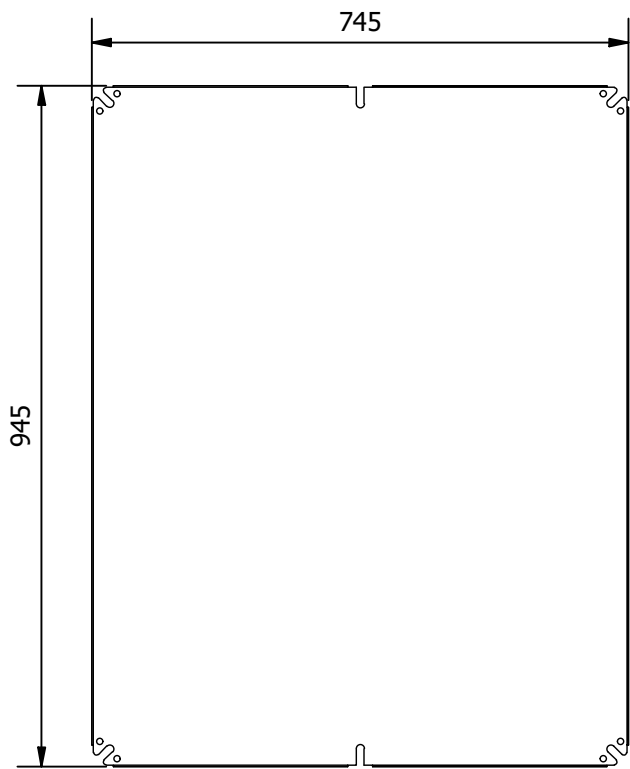

GEAR TRAY

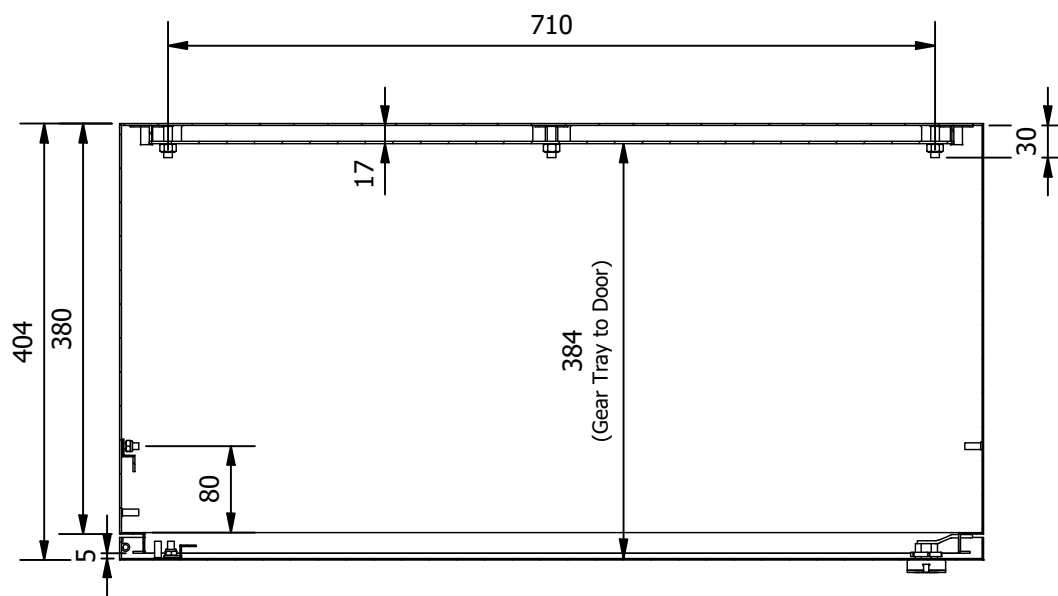

SECTION A-A

A.E. Stainless Direct
 P: 1300 533 292
 A: 4/36 Devlan St, Mansfield QLD 4122
 E: info@aestainlessdirect.com.au
 W: aestainlessdirect.com.au

DRAWING NUMBER:
SS1000x800x400

BILL OF MATERIALS

ITEM	QTY	DESCRIPTION	MATERIAL	THICKNESS
1	1	BODY	SS316N4	1.5 mm
2	1	DOOR	SS316N4	1.5 mm
3	1	GEAR TRAY	GAL - Powder Coated White	2 mm
4	2	Z-BRACKET	GAL - Powder Coated White	1.5 mm
5	6	WALL MOUNT BRACKETS	SS316N4	1.5 mm
6		GLAND PLATE (OPTIONAL)	BR, AL or SS	

ALL DIMENSIONS ARE IN MILLIMETRES.
 UNLESS OTHERWISE SPECIFIED

1/02/2021

DO NOT SCALE

THIS DRAWING INFORMATION AND ALL TECHNICAL DATA
 ENCLOSED HEREIN IS THE PROPERTY OF A.E. STAINLESS DIRECT AND IS NOT TO BE
 USED FOR REPRODUCTION, MANUFACTURE PROCUREMENT
 DISCLOSURE TO ANY PARTY WITHOUT THE WRITTEN CONSENT
 OF A.E. STAINLESS DIRECT

1 OF 2

Typical Poured Seal Detail
 Poured in Place Polyurethane

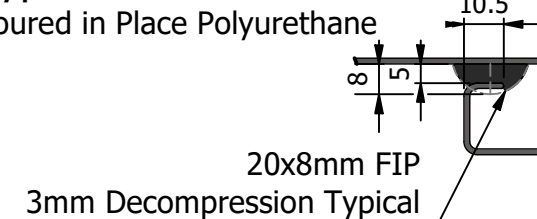

Wall Mount Bracket

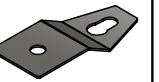

ISOMETRIC

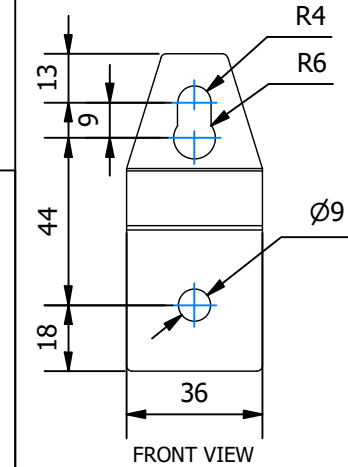

FRONT VIEW

SIDE VIEW

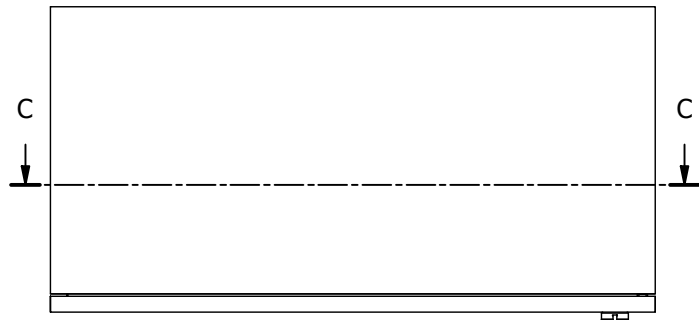

TOP VIEW

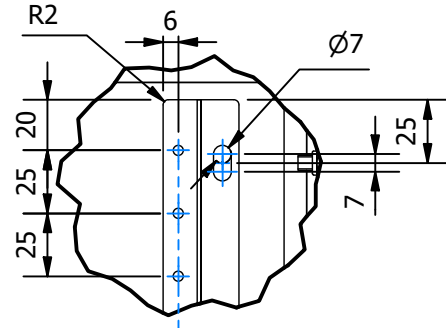

DETAIL F

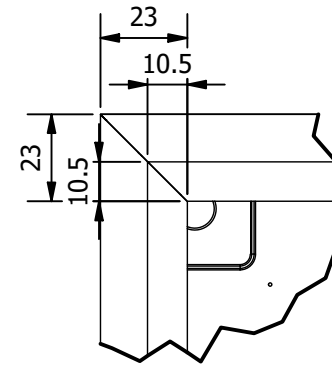

DETAIL G

ALL SEAMS TO BE SEAL WELDED FULLY, PRIOR TO POWDER COATING, TO ENSURE IP66 RATING

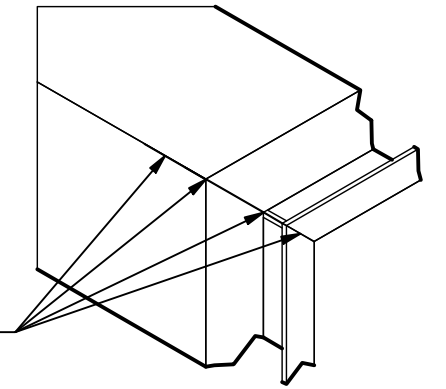

ISOMETRIC VIEW (DETAIL G)

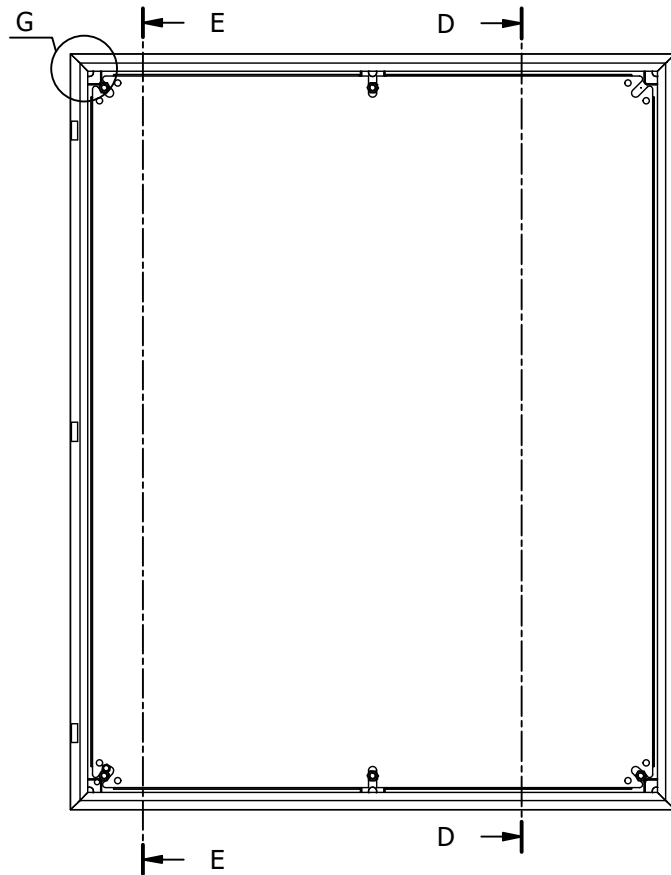

FRONT VIEW WITHOUT DOOR

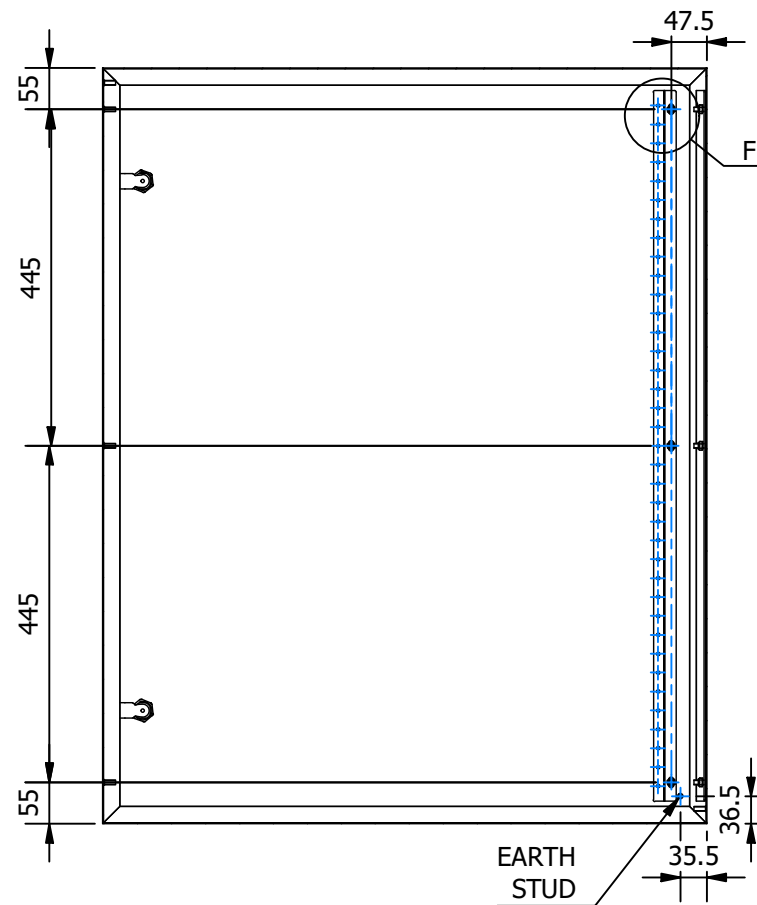

SECTION C-C

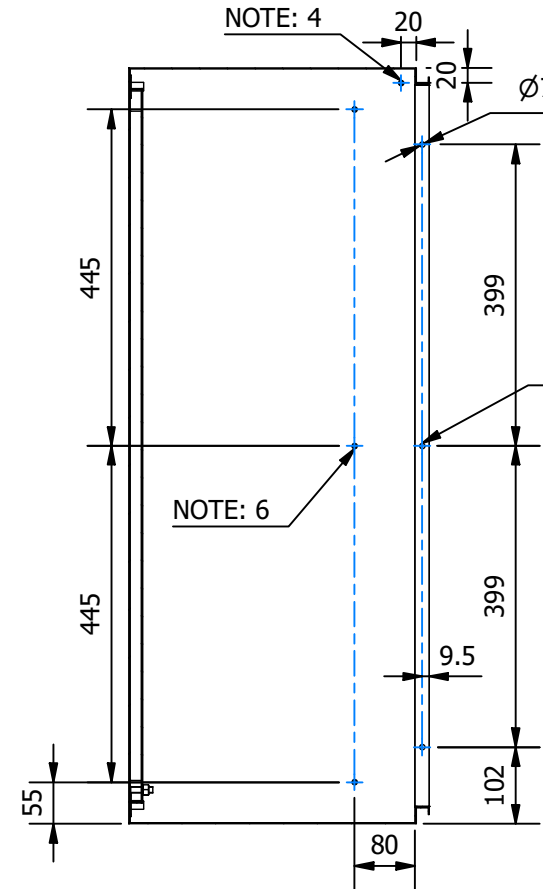

SECTION D-D

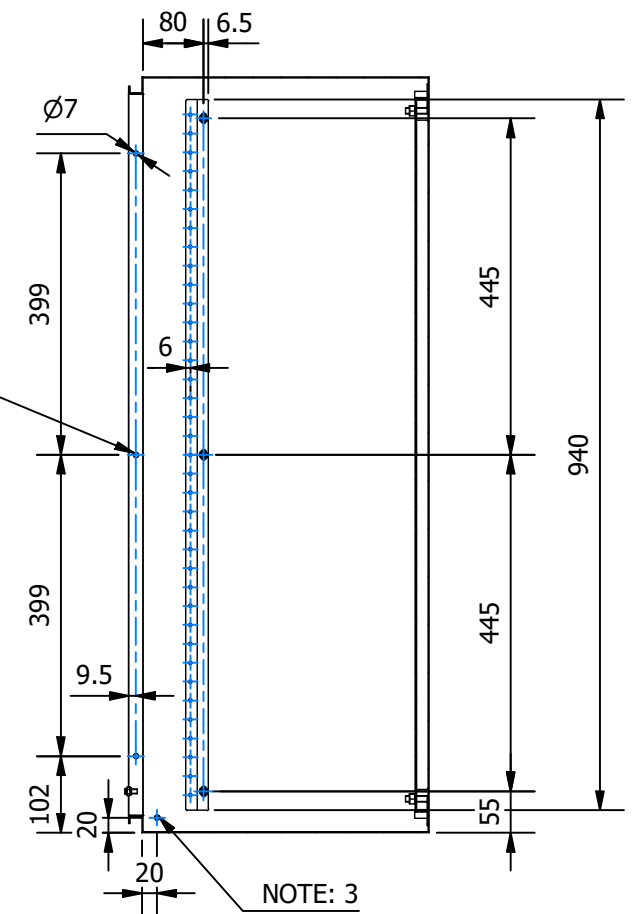

SECTION E-E

Notes:

1. Door cam to always face up when lock is in the 'Open/Unlocked' position.
2. Holes for door hinges to be on both sides to allow for left and right hinged door orientation.
3. Earth stud for when door is in the 'normal' left hand hinged orientation.
4. Earth stud for when door is in the right hand hinged orientation.
5. Open hinge holes to be fitted with same bolts as used on hinges, with added plastic washer on inside.
6. Studs for Z-Bracket when door is in the right hand hinged orientation.

P: 1300 533 292
A: 4/36 Devlan St, Mansfield QLD 4122
E: info@aestainlessdirect.com.au
W: aestainlessdirect.com.au

DRAWING NUMBER:

SS1000x800x400

ALL DIMENSIONS ARE IN MILLIMETRES. UNLESS OTHERWISE SPECIFIED

1/02/2021

DO NOT SCALE

THIS DRAWING INFORMATION AND ALL TECHNICAL DATA ENCLOSED HEREIN IS THE PROPERTY OF A.E. STAINLESS DIRECT AND IS NOT TO BE USED FOR REPRODUCTION, MANUFACTURE PROCUREMENT DISCLOSURE TO ANY PARTY WITHOUT THE WRITTEN CONSENT OF A.E. STAINLESS DIRECT

2 OF 2

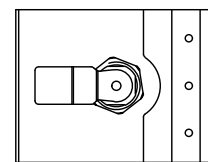

BACK OF LOCK (LOCKED POSITION)

NOTE:1

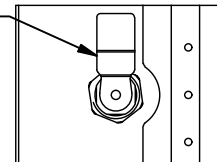

BACK OF LOCK (UNLOCKED POSITION)

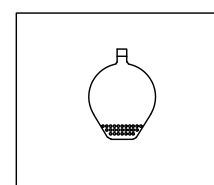

FRONT VIEW

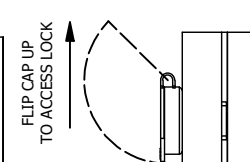

SIDE VIEW

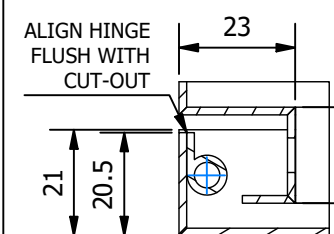

DOOR HINGE SECTION

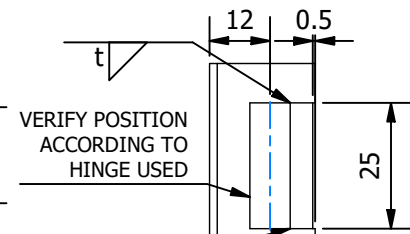

HINGE SIDE VIEW

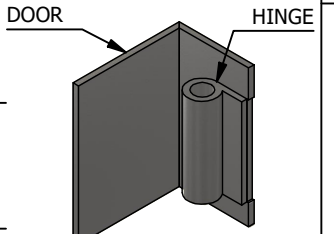

ISOMETRIC VIEW