



MOULDED GRATING PRODUCT GUIDE

GRP AUSTRALIA

FRP Moulded grating is a **one piece grating panel** manufactured in a heated mould using continuous **glass fibre rovings and resin**. The grating is ideally suited for pontoons, walkways, flooring, screening, trench covers, stair treads and industrial and mining processing plants.

Benefits of FRP Moulded Grating

- Anti Slip Flooring**
 The standard GRP Australia grating is supplied with a grit surface which has a P5 rating.
- Corrosion & Fire Resistant**
 Excellent corrosion resistance and available in several resin types to suit the application.
- Non-Magnetic and non-conductive**
 This is ideal for electrical areas
- Colours**
 Available in a range of colours. Standard colours are listed below.
- High strength to weight ratio**

Grating Product Codes

MG	38	25	G	-	I	G
Type	Mesh	Thickness	Surface	-	Resin	Colour

TYPE CODE	DESCRIPTION
MG	Moulded Grating
PG	Pultruded Grating (Contact GRP Australia)

MESH CODE	DESCRIPTION	OPEN AREA %	COLOUR CODE	DESCRIPTION	COLOUR
13	13 x 13 Heel Guard	30%	G	Grass Green RAL6010	
19	19 x 19 Mini Mesh	40%	LG	Grey RAL9006	
20	20 x 20 Micro Mesh	42%	SG	Slate Grey RAL7015	
38	38.1 x 38.1 Standard	56-78%	Y	Signal Yellow RAL1003	
50	50 x 50 Mesh	78-82%	BG	Black Grey RAL7021	
83	83 x 83 Mesh	84%			

*Alternative colours available on request
10-12 Week Leadtime required



Cost
Competitive



Non-corrosive &
rot resistant



As strong as
steel



Termite and
vermin proof



High fire
resistance









UV
Stabilised



Lightweight & easy
to manoeuvre

Grating Surface Finish & Resin Options

	SURFACE TYPE	SURFACE CODE	GENERAL PROPERTIES	SLIP RATING AS4586:2013
	Concave Finish	C	Natural finish with slight concave profile on load bars	P5
	Flat Surface	FS	13x13 & 19x19 Moulded grating ground to a smooth flat surface (Thickness of grating may be 2-3mm shorter due to no grit)	P2
			38x38 Moulded grating ground to a smooth flat surface (Thickness of grating may be 2-3mm shorter due to no grit)	P4
	Fine Grit	FG	A fine grit surface finish which requires the surface to be ground smooth to remove the concave finish before applying fine sand.	P5
	Glass Beaded	GB	A refined grit surface finish which requires the surface to be ground smooth to remove the concave finish before applying fine sand.	P5
	Standard Grit	G	Standard non-slip grit surface	P5
	Diamond Top	DT3 or DT5	Flat top plate with raised tread pattern to maximise grip. Diamond Top thickness 3 or 5mm. Plate thickness adds to the overall thickness of the grating	P5
	Grit Top Cover	GT3 or GT5	Grit Top Plate. 3mm or 5mm thick top plate. Plate thickness adds to the overall thickness of the grating	P5

RESIN TYPE	RESIN CODE	GENERAL PROPERTIES	FLAME SPREAD RATING ASTM E84	
IFR25	I	Isophthalic Polyester	Standard grating resin type. Very good chemical resistance and good flame resistance. Good general purpose resin suitable for most applications.	Class 1, 25, or less
VER25	V	Vinyl Ester	Excellent chemical resistance and good flame resistance. Suitable for applications in aggressive environments and higher temperatures.	Class 1, 25, or less
IFR10	I10	Isophthalic Polyester	Refer to IFR25. Superior flame resistance.	
VER10	V10	Vinyl Ester	Refer to VER25. Superior flame resistance.	

Moulded Grating Heel Guard 13x13 / 40x40

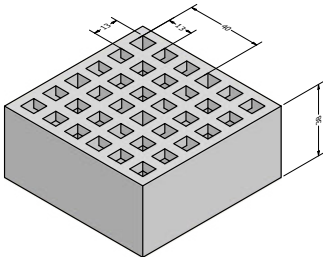

Public spaces, commercial & residential. Suitable for pets and high heels

PRODUCT CODE	THICKNESS (T)	BAR SIZE (MM)	*STD. PANEL SIZE (MM)	WEIGHT (KG/M ²)
MG1325	25	6.5/5	1007 x 3007 1247 x 4047	17.8
MG1330	30	6.5/5	1007 x 3007 1247 x 4047	19.1
MG1338	38	6.5/5	1007 x 3007 1247 x 4047	23.8

*Other panel sizes available on request.

Moulded Grating Mini Mesh 19x19 / 38x38

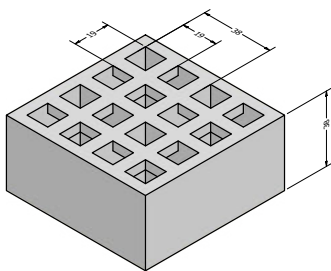

Public spaces, commercial, residential, industrial and mining applications.

PRODUCT CODE	THICKNESS (T)	BAR SIZE (MM)	*STD. PANEL SIZE (MM)	WEIGHT (KG/M ²)
MG1925	25	6.5/5	1226 x 2440 1226 x 3665	16.8
MG1930	30	6.5/5	1226 x 3665	18.8
MG1938	38	6.5/5	1226 x 2440 1226 x 3665	23.5

*Other panel sizes available on request.

Moulded Grating 38x38

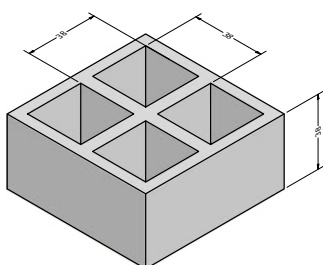

Industrial and mining applications. Not suitable for pets and high heels.

PRODUCT CODE	THICKNESS (T)	BAR SIZE (MM)	*STD. PANEL SIZE (MM)	WEIGHT (KG/M ²)
MG3813	13	6/5	1226 x 3665	6
MG3815	15	6/5	615 x 3665	7
MG3820	20	6/5	1226 x 3665	9.8
MG3825	25	6.5/5	1226 x 3665	12.3
MG3830	30	6.5/5	1226 x 3665	14.6
MG3838	38	7/5	1226 x 3665	19.5
MG3850	50	9.5/7.5	1226 x 3665	42

*Other panel sizes available on request.

Moulded Grating Micro Mesh 20x20 / 40x40

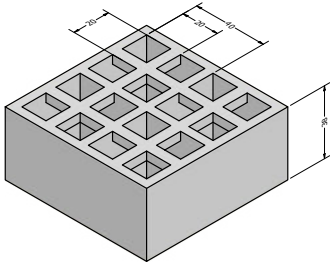

Public spaces, commercial, residential, industrial and mining applications.

PRODUCT CODE	THICKNESS (T)	BAR SIZE (MM)	*STD. PANEL SIZE (MM)	WEIGHT (KG/M ²)
MG2025	25	6.5/5	1007 x 3007 1247 x 4047	16.8
MG2030	30	6.5/5	1007 x 3007 1247 x 4047	18.3
MG2038	38	6.5/5	1007 x 3007 1247 x 4047	23.2

*Other panel sizes available on request.

Moulded Grating 50x50

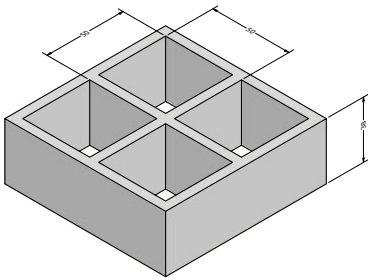

Public spaces, commercial, industrial and mining applications.

PRODUCT CODE	THICKNESS (T)	BAR SIZE (MM)	*STD. PANEL SIZE (MM)	WEIGHT (KG/M ²)
MG5015	15	6/5	1228 x 3666 1228 x 4020	5.9
MG5025	25	7/6	1230 x 4020	11.5
MG5040	40	6.8/5	1787 x 4020	17.5
MG5050	50	8/6	1230 x 4020 1532 x 4020	23.7

*Other panel sizes available on request.

Moulded Grating 83x83

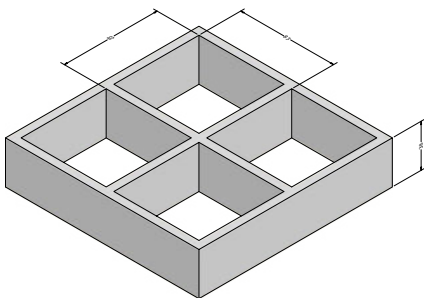

Public spaces, commercial, industrial and mining applications.

PRODUCT CODE	THICKNESS (T)	BAR SIZE (MM)	*STD. PANEL SIZE (MM)	WEIGHT (KG/M ²)
MG8338	38	6.5/5	1007 x 3007 1007 x 4007	10
MG8340	40	6.5/5	1007 x 3007 1007 x 4007	11

*Other panel sizes available on request.

Diamond Top Cover Moulded Grating - 38x38

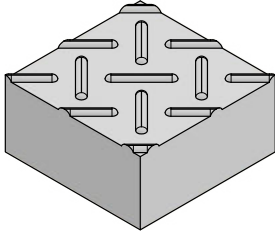

Public spaces, commercial, industrial and mining applications.

PRODUCT CODE	THICKNESS (T)	BAR SIZE (MM)	PANEL SIZE (MM)	WEIGHT (KG/M ²)
MG3828DT3	28	6.5/5	1226 X 3665	18.0
MG3833DT3	33	6.5/5	1226 X 3665	20.3
MG3841DT3	41	6.5/5	1226 X 3665	25.2

*Other panel sizes available on request.

Grit Top Cover Moulded Grating - 38x38

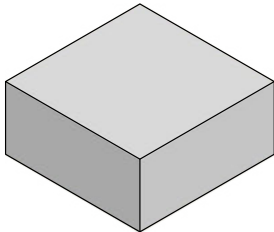

Public spaces, commercial, industrial and mining applications.

PRODUCT CODE	THICKNESS (T)	BAR SIZE (MM)	PANEL SIZE (MM)	WEIGHT (KG/M ²)
MG3828GT3	28	6.5/5	1226 X 3665	18.0
MG3833GT3	33	6.5/5	1226 X 3665	20.3
MG3841GT3	41	6.5/5	1226 X 3665	25.2

*Other panel sizes available on request.

Reference Guide for Moulded Grating Profiles

The tables below are a quick reference guide for grating profile selection. The tables assume a maximum grating deflection of under 5mm for the stated UDL and point load. The reference loads used are from AS/NZS 1170.1 2002 and consideration must be given to any additional loads which may be imposed.

Typical Domestic and Residential Applications General areas.

UDL 2KPa, Point Load 1.8kN	
SPAN mm	Suitable Grating Profiles
450	MG1325, MG1330, MG1338, MG1925, MG1930, MG1938, MG3820, MG3825, MG3838, MG3850
600	MG1325, MG1330, MG1338, MG1925, MG1930, MG1938, MG3820, MG3825, MG3838, MG3850
900	MG1330, MG1338, MG1930, MG1938, MG3838, MG3850
1200	MG1338, MG1938, MG3838, MG3850

Balconies and Roofs with Communal Access and Public Walking Tracks.

UDL 4KPa, Point Load 1.8kN	
SPAN mm	Suitable Grating Profiles
450	MG1325, MG1330, MG1338, MG1925, MG1930, MG1938, MG3820, MG3825, MG3838, MG3850
600	MG1325, MG1330, MG1338, MG1925, MG1930, MG1938, MG3825, MG3838, MG3850
900	MG1330, MG1338, MG1930, MG1938, MG3838, MG3850
1200	CONTACT GRP AUSTRALIA FOR ALTERNATIVE SOLUTIONS

Public Areas where people may Congregate including footpaths, landings and terraces subject to wheeled vehicles.

UDL 5KPa, Point Load 4.5kN	
SPAN mm	Suitable Grating Profiles
450	MG1325, MG1330, MG1338, MG1925, MG1930, MG1938, MG3825, MG3838, MG3850
600	MG1330, MG1338, MG1930, MG1938, MG3838, MG3850
900	MG1338, MG1938, MG3838, MG3850
1200	CONTACT GRP AUSTRALIA FOR ALTERNATIVE SOLUTIONS

Tables below are loading tables for both Mini Mesh (19x19) and Heel Guard (13x13). These tables are calculated using a line load and a Uniformly Distributed Load acting at the different span widths and the various thicknesses.

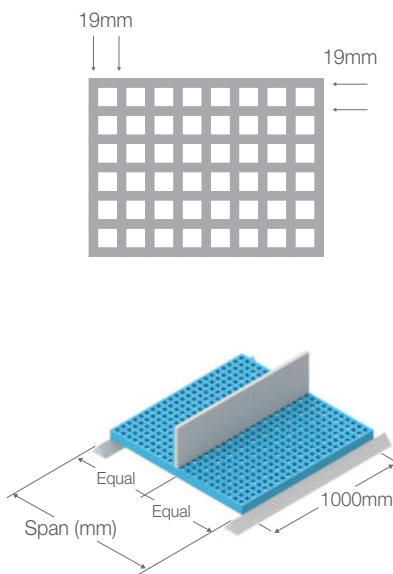

SPAN mm	CODE	THK. mm	Concentrated Line Load kN/m - Deflection in mm								
			1.5	1.8	2.7	3.5	4.5	7	10	13	
300	MG1925	25	<0.5	<0.5	<0.5	0.5	0.7	1.1	1.5	2.0	
	MG1930	30	<0.5	<0.5	<0.5	<0.5	<0.5	0.6	0.9	1.1	
450	MG1925	25	0.8	0.9	1.4	1.8	2.3	3.6	5.2	6.7	
	MG1930	30	<0.5	0.5	0.8	1.0	1.3	2.1	3.0	3.9	
	MG1938	38	<0.5	<0.5	<0.5	0.5	0.7	1.1	1.5	2.0	
600	MG1925	25	1.8	2.2	3.3	4.3	5.5	8.6	12.3		
	MG1930	30	1.1	1.3	1.9	2.5	3.2	4.9	7.0	9.1	
	MG1938	38	0.5	0.6	1.0	1.2	1.6	2.5	3.6	4.6	
900	MG1925	25	6.2	7.5	11.2						
	MG1930	30	3.6	4.3	6.4	8.3	10.7				
	MG1938	38	1.8	2.2	3.2	4.2	5.4	8.4	12.0		
1200	MG1925	25	14.7								
	MG1930	30	8.4	10.1							
	MG1938	38	4.3	5.1	7.7	10.0	12.8				

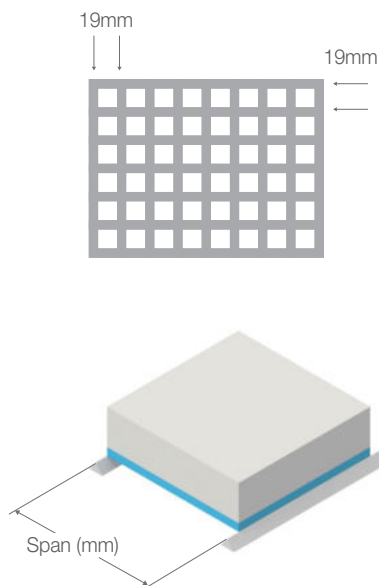

SPAN mm	CODE	THK. mm	Uniform Distributed Load kPa - Deflection in mm								
			1.5	2.5	3	5	7.5	10	15	20	
300	MG1925	25	<0.5	<0.5	<0.5	<0.5	<0.5	<0.5	<0.5	<0.5	0.6
	MG1930	30	<0.5	<0.5	<0.5	<0.5	<0.5	<0.5	<0.5	<0.5	<0.5
450	MG1925	25	<0.5	<0.5	<0.5	0.7	1.1	1.5	2.2	2.9	
	MG1930	30	<0.5	<0.5	<0.5	<0.5	0.6	0.8	1.3	1.7	
	MG1938	38	<0.5	<0.5	<0.5	<0.5	<0.5	<0.5	0.6	0.8	
600	MG1925	25	0.7	1.2	1.4	2.3	3.5	4.6	6.9	9.2	
	MG1930	30	<0.5	0.7	0.8	1.3	2.0	4.6	4.0	5.3	
	MG1938	38	<0.5	<0.5	<0.5	0.7	1.0	1.3	2.0	2.7	
900	MG1925	25	3.5	5.8	7.0	11.7					
	MG1930	30	2.0	3.3	4.0	6.7	10.0	13.3			
	MG1938	38	1.0	1.7	2.0	3.4	5.1	5.8	10.2	13.5	
1200	MG1925	25	11.0								
	MG1930	30	6.3	10.5	12.7						
	MG1938	38	3.2	5.3	6.4	10.7	16.0				

The tables below are loading tables for our standard 38x38 moulded grating. The two loading options are Uniformly Distributed Load and a point load approximately equal to the line load.

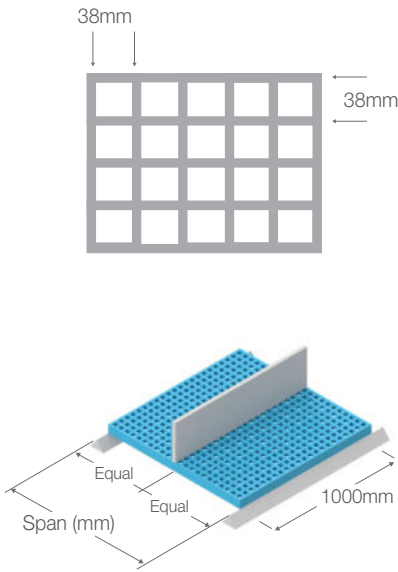

SPAN mm	CODE	THK. mm	Concentrated Line Load kN/m - Deflection in mm								
			1.5	1.8	2.7	3.5	4.5	7	10	13	
300	MG3820	20	<0.5	0.6	0.9	1.1	1.5	2.3	3.2	4.2	
450	MG3820	20	1.6	2.0	3.0	3.8	4.9	7.7	10.9		
	MG3825	25	0.7	0.8	1.2	1.6	2.0	3.1	4.4	5.8	
	MG3830	30	0.5	0.6	1.0	1.3	1.6	2.5	3.6	4.7	
600	MG3820	20	3.9	4.7	7.0	9.1	11.7				
	MG3825	25	1.6	1.9	2.8	3.7	4.7	7.4	10.5		
	MG3830	30	1.3	1.5	2.3	3.0	3.8	6.0	8.5	11.1	
	MG3838	38	0.7	0.8	1.2	1.6	2.1	3.2	4.6	6.0	
900	MG3825	25	5.3	6.4	9.6	12.4					
	MG3830	30	4.3	5.2	7.8	10.1	13.0	20.2			
	MG3838	38	2.3	2.8	4.2	5.5	7.0	10.9	15.6		
	MG3850	50	0.6	0.7	1.1	1.4	1.8	2.8	4.0	5.2	
1200	MG3830	30	10.3	12.3							
	MG3838	38	5.5	6.7	10.0	12.9					
	MG3850	50	1.4	1.7	2.5	3.3	4.2	6.6	9.4	12.3	

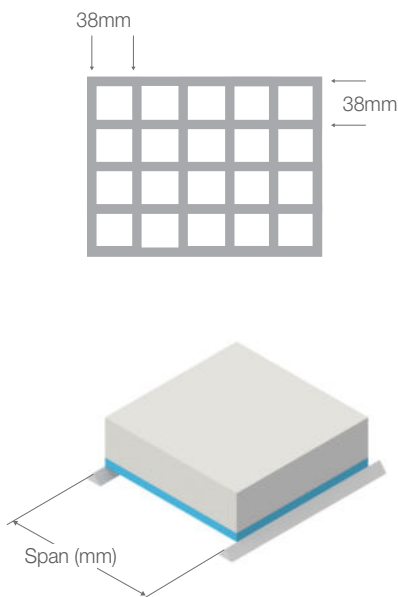

SPAN mm	CODE	THK. mm	Uniform Distributed Load kPa - Deflection in mm							
			1.5	2.5	3	5	7.5	10	15	20
300	MG3820	20	<0.5	<0.5	<0.5	<0.5	<0.5	2.3	3.2	4.2
450	MG3820	20	<0.5	0.8	0.9	1.5	2.3	3.1	4.6	6.1
	MG3825	25	<0.5	<0.5	<0.5	0.6	0.9	1.2	1.9	2.5
	MG3830	30	<0.5	<0.5	<0.5	0.5	0.8	1.0	1.5	2.0
600	MG3820	20	1.5	2.4	2.9	4.9	7.3	9.7		
	MG3825	25	0.6	1.0	1.2	2.0	3.0	3.9	5.9	7.9
	MG3830	30	<0.5	0.8	1.0	1.6	2.4	3.2	4.8	6.4
	MG3838	38	<0.5	<0.5	0.5	0.9	1.3	1.7	2.6	3.5
900	MG3825	25	7.4	12.3	14.8	24.6				
	MG3830	30	2.4	4.1	4.9	8.1	12.2	16.2		
	MG3838	38	1.3	2.2	2.6	4.4	6.6	8.8	13.2	
	MG3850	50	<0.5	0.6	0.7	1.1	1.7	2.2	3.4	4.5
1200	MG3830	30	7.7	12.8						
	MG3838	38	4.2	6.9	8.3	13.9				
	MG3850	50	1.1	1.8	2.1	3.5	5.3	7.1	10.6	14.2

Solid Top Moulded Grating (GT3 and DP3). Top grid 38x38 with 3mm solid top. Various grating thickness as noted. For square mesh grating, point load is approximately equal to line load.

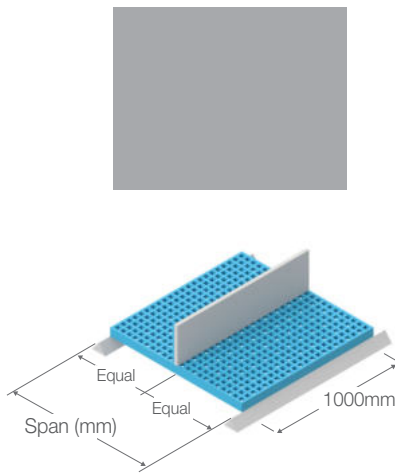

SPAN mm	CODE	THK. mm	Concentrated Line Load kN/m - Deflection in mm							
			1.5	2.5	3	5	7.5	10	15	20
450	MG3828GT3	28	<0.5	0.5	0.8	1.1	1.4	2.1	3.0	3.9
	MG3833GT3	33	<0.5	<0.5	<0.5	0.6	0.8	1.2	1.8	2.3
	MG3841GT3	41	<0.5	<0.5	<0.5	<0.5	<0.5	0.7	1.0	1.3
600	MG3828GT3	28	1.1	1.3	1.9	2.5	3.2	5.0	7.1	
	MG3833GT3	33	0.6	0.8	1.1	1.5	1.9	2.9	4.2	5.5
	MG3841GT3	41	<0.5	<0.5	0.6	0.8	1.0	1.6	2.3	3.0
900	MG3828GT3	28	3.6	4.3	6.5	8.4	10.8			
	MG3833GT3	33	2.1	2.6	3.8	5.0	6.4			
	MG3841GT3	41	1.2	1.4	2.1	2.7	3.5	5.5	7.8	10.2
1200	MG3828GT3	28	8.6	10.3						
	MG3833GT3	33	5.0	6.1	9.1	11.8				
	MG3841GT3	41	2.8	3.3	5.0	6.5	8.3			

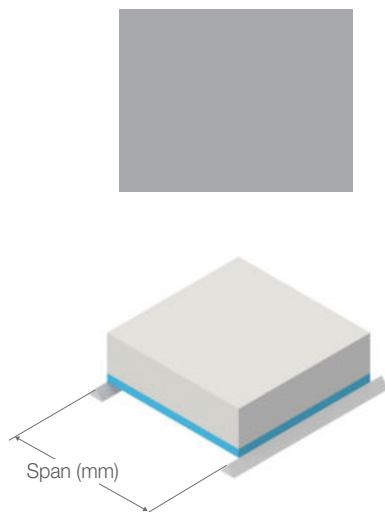

SPAN mm	CODE	THK. mm	Uniform Distributed Load kPa - Deflection in mm							
			1.5	2.5	3	5	7.5	10	15	20
450	MG3828GT3	28	<0.5	<0.5	<0.5	<0.5	0.6	0.8	1.3	1.7
	MG3833GT3	33	<0.5	<0.5	<0.5	<0.5	<0.5	<0.5	0.7	1.0
	MG3841GT3	41	<0.5	<0.5	<0.5	<0.5	<0.5	<0.5	<0.5	<0.5
600	MG3828GT3	28	<0.5	0.7	0.8	1.3	2.0	2.7	4.0	5.4
	MG3833GT3	33	<0.5	<0.5	<0.5	0.8	1.2	1.6	2.4	3.2
	MG3841GT3	41	<0.5	<0.5	<0.5	<0.5	0.7	0.9	1.3	1.7
900	MG3828GT3	28	2.0	3.4	4.1	6.8	10.2	13.6		
	MG3833GT3	33	1.2	2.0	2.4	4.0	6.0	8.0	12.0	
	MG3841GT3	41	0.7	1.1	1.3	2.2	3.3	4.4	6.6	8.8
1200	MG3828GT3	28	6.4	10.7	12.9					
	MG3833GT3	33	3.8	6.3	7.6	12.6				
	MG3841GT3	41	2.1	3.5	4.2	6.9	10.4	10.4	13.9	

The primary consideration in the selection of FRP grating, particularly for walkways, is deflection rather than the ultimate strength. This is because even though FRP grating has a high ultimate strength it has a relatively low modulus of elasticity compared to steel and aluminium. Contact GRP Australia for more detailed load tables if required.

Clip Descriptions - Standard Grating

Refer to following page for fastening options

CLIP TYPE	DESCRIPTION	ISOMETRIC VIEW	FASTENING OPTIONS	MATERIAL
CM5025	'M' Clip for 25 to 40 mm thick moulded grating, 50x50 mesh. Fastener hole 8.5mm.		1,3,4	316ss
CM3813	'M' Clip for 13 to 38mm thick moulded grating, 38x38 mesh. Fastener hole 8.5mm.		1,3,4	316ss
CM3820	'M' Clip for 20 to 38mm thick moulded grating, 38x38 mesh. Fastener hole 8.5mm.		1, 3, 4	316ss
CM3838	'M' Clip for 38 to 50mm thick moulded grating, 38x38 mesh. Fastener hole 8.5mm.		1, 3, 4	316ss
CC3825	'C' Clip for 25mm thick moulded grating. Suitable for M6 x 40 fastener.		2	316ss
CC3838	'C' Clip for 38mm thick moulded grating. Suitable for M6 x 40 fastener.		2	316ss
CL3825	'L' Clip for 25 to 38mm thick moulded grating. Fastener hole 8.5mm.		1, 3, 4	316ss
CJ3838	'J' Clip for 38 to 50mm thick moulded grating, Standard 38x38. Fastener slot 8mm (will require a hex nut and washer)		3, 4	316ss

Clip Descriptions - For Mini Mesh and Heel Guard Grating

CLIP TYPE	DESCRIPTION	ISOMETRIC VIEW	FASTENING OPTIONS	MATERIAL
CJ1938	'J' Clip for 38 to 50mm thick moulded grated, 19x19 Minimesh. Fastener slot 5mm (will require a square nut)		6,7	316ss
CM1915	'M' Clip for 25 to 38mm thick moulded grating, 19x19 mini mesh. Fastener hole 5.5mm.		5, 6	316ss
CM1920	'M' Clip for 25 to 38mm thick moulded grating, 19x19 mini mesh. Fastener hole 5.5mm.		5, 6	316ss
CM1925	'M' Clip for 25 to 38mm thick moulded grating, 19x19 mini mesh. Fastener hole 5.5mm.		5, 6	316ss
CR30	Round recessed washer for 19x19 mini mesh and heelguard. Fastener hole 8mm. 30mm outer diameter		3, 5, 8	316ss
CR45	Round recessed washer for 19x19 mini mesh and heelguard. Fastener hole 8mm. 45mm outer diameter		3, 5, 8	316ss

Clip Fastening Options

1	2	3	4	5
M6-11x50 Grip & Roof Screw M6-11 x 50mm Buildex Climaseal H/Head Hi-Grip with Seal Roof Zip Screws (Pair w/Dome Sealing Washer)	M6 x 40 316ss Available as Socket head or Torx head	M8 x 40 316ss Available as Socket head or Torx head (Pair w/ M8 nut and washer.)	M8 x 40 316ss Available as Soc Cap Screw (Pair w/ M8 nut and washer.)	10G x 50 G550 Available as Wafer XR Self Drilling Metal Screw (Suitable w/Metal, FRP)
6	7	8	9	
8G x 35 G550 Available as a Pan XR Self Drilling Metal Screw (Suitable w/Metal, FRP)	CX8-60 304ss 8 x 60 mm w/full thread. Available as a washer head Screw (Suitable w/Timber, FRP)	CX6-80 304ss 6 x 80 mm w/60mm thread. Available as a washer head Screw (Suitable w/Timber, FRP)	8x90 Anchor Bolt Available as Counter Sunk Fischer A4 Screw Bolt (Suitable w/Concrete)	

Clip Fastening & Installation Methods

To ensure ease of installation, please review all relevant technical documentation. Take care when fastening and seek assistance if required. For further info regarding installation please contact the team at GRP Australia. The section below illustrates standard installation methods that can be applied to moulded grating. Clip and fastening selections should be made according to the substrate material in use.

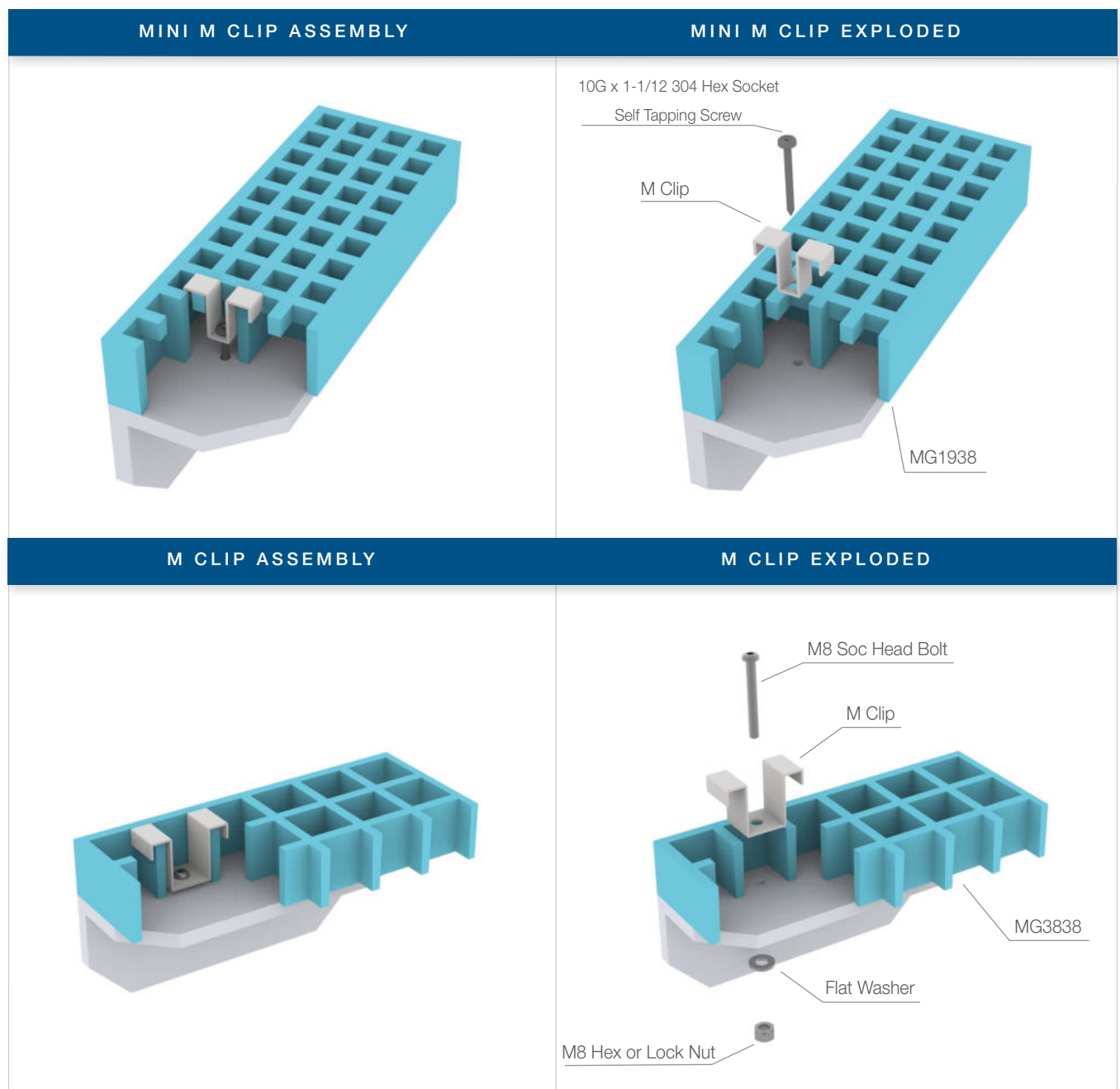

L CLIP ASSEMBLY

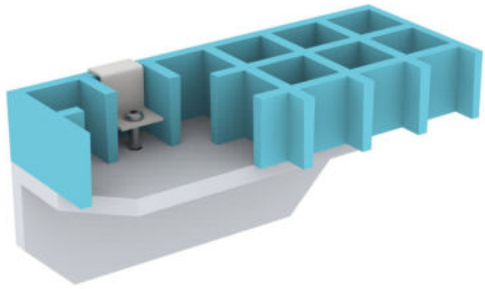

L CLIP EXPLODED

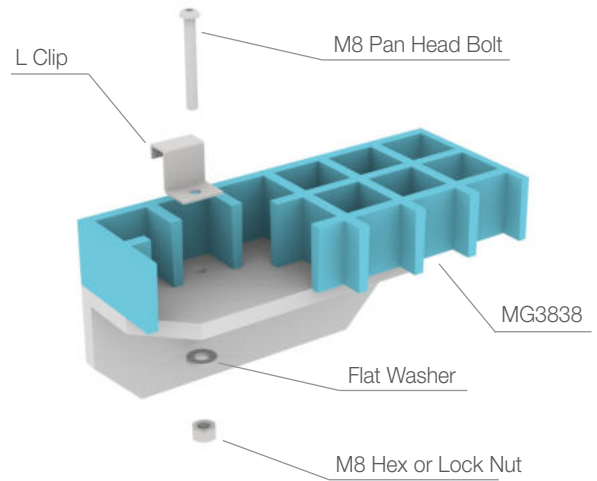

C CLIP ASSEMBLY

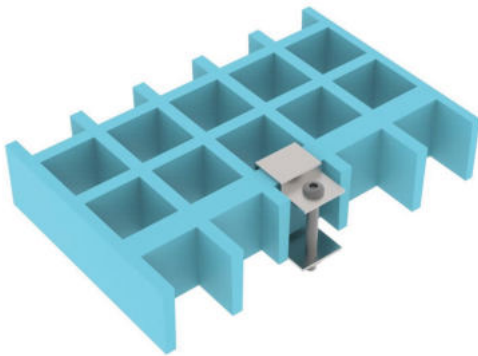

C CLIP EXPLODED

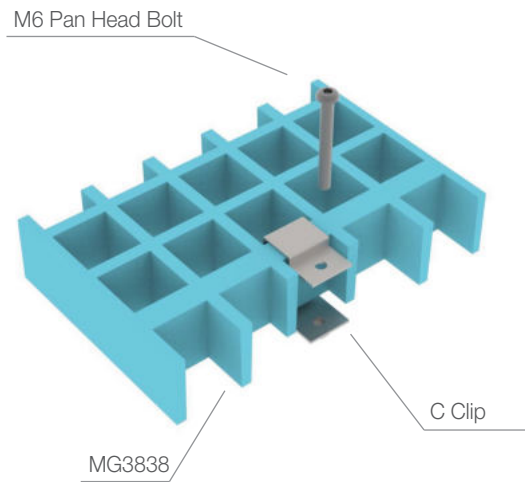

R CLIP ASSEMBLY

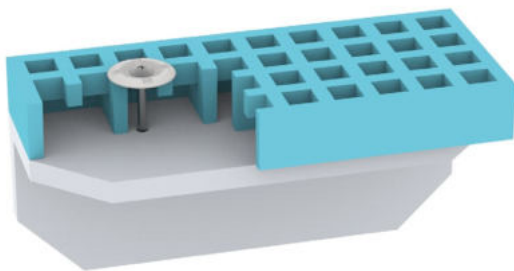

R CLIP EXPLODED

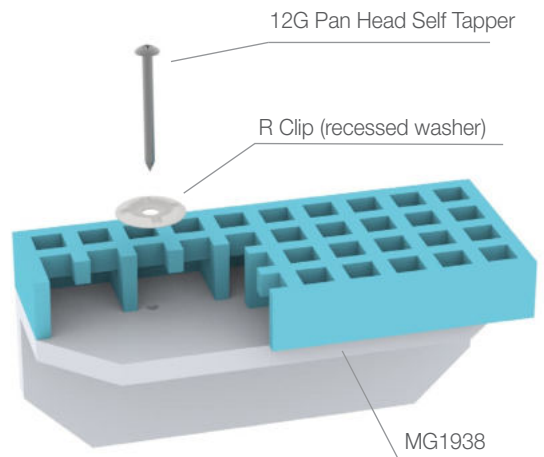

MJ CLIP ASSEMBLY

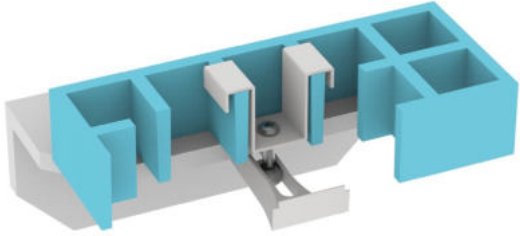

MJ CLIP EXPLODED

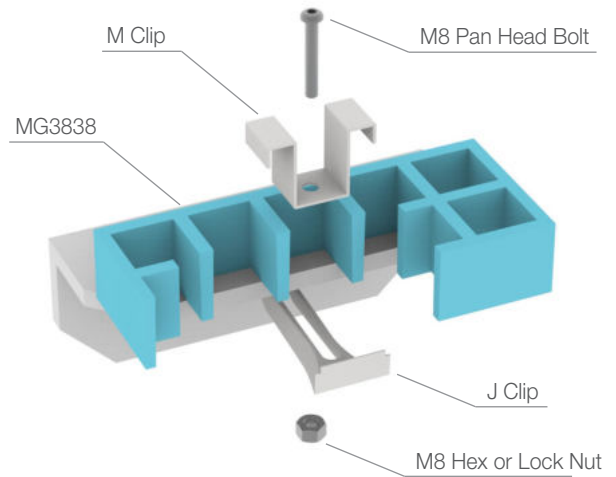

HEEL GUARD ASSEMBLY

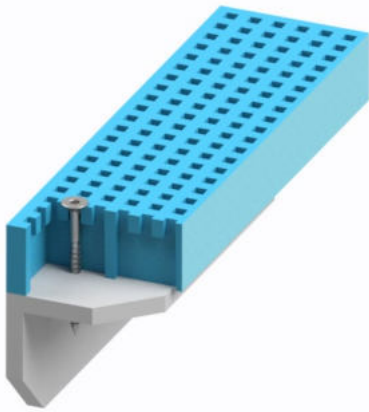

HEEL GUARD EXPLODED

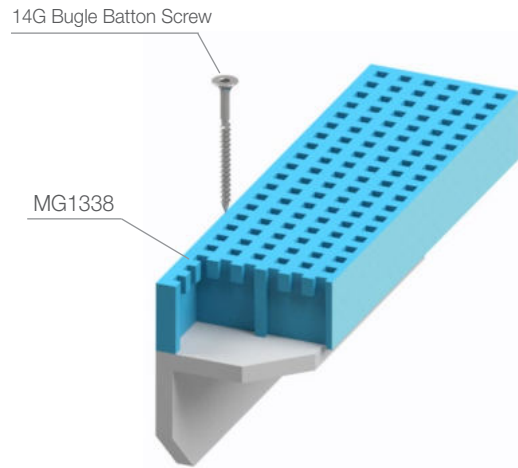

HEEL GUARD ASSEMBLY

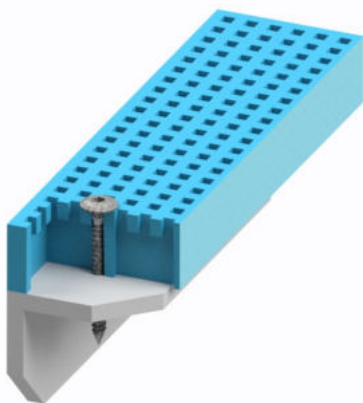

HEEL GUARD EXPLODED

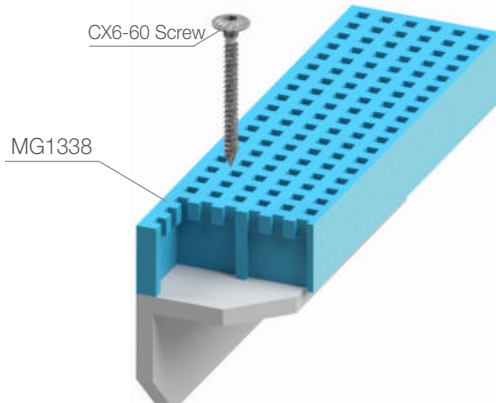

Please note the above illustrations are simply a guide that show one example of how each clip can be installed. Clips can be paired with several types of grating and fasteners. Select the most appropriate method according to design.

Adjustable Height Pedestals

Adjustable height pedestals can be used for raised FRP grating floors, available in a range of sizes. The pedestals are suitable for uneven ground or flooring.



PRODUCT CODE	HEAD DIA	BOTTOM DIA	HEIGHT RANGE	WORKING LOADING
GP160	155MM	225MM	160-225MM	1500KGS
GP115	155MM	175MM	115-170MM	1500KGS

GRP stair treads are made from either **moulded grating** or **pultruded grating** with an integral moulded non slip solid top leading edge. The advantages of FRP treads are that have a high corrosion resistance, are non slip, and long lasting. FRP treads can be supplied in a variety of sizes, colours, and grating types. Our **standard treads are noted below**. GRP Australia can assist you with custom stair treads.

Standard Stair Treads

Custom stair treads can be made to order.

CODE	MESH SIZE (MM)	TREAD THICKNESS (MM)	RESIN	TREAD WIDTH (MM)	TREAD LENGTH (MM)
ST3838G	38x38	38	IFR-25	275	As req. max recommended span approx. 900mm
ST1938G	19x19	38	IFR-25	275	As req. max recommended span approx. 900mm
ST1338G	13x13	38	IFR-25	275	As req. max recommended span approx. 900mm

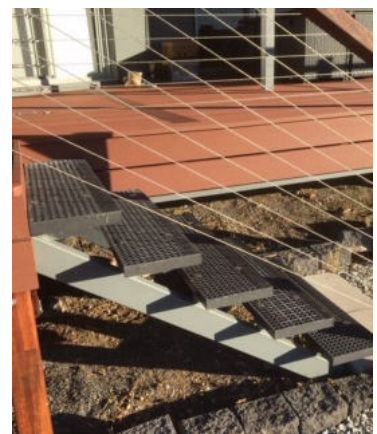

CHEMICAL ENVIRONMENT	% CONC.	TEMP. °C	VINYL ESTER	ISOPHTHALIC
Acetic Acid	50	MAX	C	C
Acetone	100	24	F	I
Aluminium Hydroxide	ALL	MAX	C	C
Aluminium Chloride	ALL	MAX	C	C
Ammonium Chloride	ALL	50	C	C
Ammonium Bicarbonate	15	50	C	C
Ammonium Bicarbonate	50	50	C	C
Ammonium Hydroxide	20	26	F	N
Ammonium Sulphate	ALL	50	C	C
Barium Sulphate	ALL	MAX	C	C
Benzene	100	65	I	I
Benzoic Acid (SAT)	SAT	MAX	C	C
Borax (SAT)	SAT	MAX	C	C
Calcium Carbonate	ALL	MAX	C	C
Calcium Hydroxide	25	MAX	C	F
Calcium Hypochlorite	ALL	MAX	C	I
Calcium Nitrate	ALL	MAX	C	C
Carbon Tetrachloride	100	26	I	N
Chlorine - Dry Gas	ALL	MAX	C	C
Chlorine Water (SAT)	SAT	50	C	I
Chromic Acid	50	65	I	N
Citric Acid	ALL	MAX	C	C
Copper Chloride	ALL	MAX	C	C
Copper Cyanide	ALL	60	C	F
Copper Nitrate	ALL	MAX	C	C
Crude Oil (Sweet or Sour)	ALL	MAX	C	C
Diesel Fuel	ALL	37	C	C
Ethanol	10	50	C	F
Ethanol	50	50	C	I
Ethanol Glycol	ALL	65	C	C
Ferric Chloride	100	MAX	C	C
Ferric Nitrate	ALL	MAX	C	C
Ferrous Chloride	ALL	MAX	C	C
Fluoro silicic Acid	10	24	C	C
Formaldehyde (0-50%)	50	50	F	I
Gasoline	ALL	50	C	C

Glucose	ALL	50	C	C
Glycerin	100	MAX	C	C
Hydrobromic Acid	50	MAX	F	F
Hydrobromic Acid	10	MAX	C	F
Hydrobromic Acid	37	MAX	C	F
Hydrogen Peroxide	30	26	C	N
Lactic Acid	100	MAX	C	C
Lithium Chloride (SAT)	SAT	MAX	N	N
Magnesium Chloride	ALL	MAX	C	C
Magnesium Nitrate	ALL	MAX	C	C
Magnesium Sulphate	ALL	MAX	C	C
Mercuric Chloride	ALL	MAX	C	C
Mercurous Chloride	ALL	MAX	C	C
Nickle Chloride	ALL	MAX	C	C
Nickle Sulphate	ALL	MAX	C	C
Nitric Acid	20	50	F	F
Oxalic Acid	ALL	65	C	C
Perchloric Acid	30	32	F	I
Phosphoric Acid	80	MAX	C	C
Potassium Chloride	ALL	MAX	C	C
Potassium Dichromate	ALL	MAX	C	C
Potassium Nitrate	ALL	MAX	C	C
Potassium Sulphate	ALL	MAX	C	C
Propylene Glycol	ALL	MAX	C	C
Sodium Acetate	ALL	MAX	C	C
Sodium Bisulfate	ALL	26	F	F
Sodium Bromide	ALL	26	C	C
Sodium Cyanide	ALL	26	C	I
Sodium Hydroxide	10	MAX	C	I
Sodium Hydroxide	50	MAX	F	N
Sodium Nitrate	ALL	MAX	C	C
Sodium Sulphat	ALL	MAX	C	C

C

Continuous exposure of the grating to the Chemical Environment listed at the Temperature listed.

F

Frequent exposure of the grating to splashes and spills from the Chemical Environment listed with that environment at the Temperature listed.

I

Infrequent exposure of the grating to splashes and spills from the Chemical Environment listed with that environment at the Temperature listed and the spill immediately cleaned up or washed from the grating.

N

Not recommended for the Concentrations and Temperatures listed.

MAX Temperature is **85 °C** for Vinyl grating.

MAX Temperature is **70 °C** for Isophthalic grating.

GRP Australia believes the data to be true and accurate but no guarantee is expressed or implied as to specific performance. Testing for specific environments is recommended. Responsibility for claims arising from breach of warranty, negligence or otherwise is limited to the purchase price of the material sold.



GRP AUSTRALIA

L: 25 Shannon Place, Virginia QLD

E: sales@grpaustralia.com.au

P: 07 3252 1244